

Communication System Lab
(EE-226-F)
LAB MANUAL
IV SEMESTER



RAO PAHALD SINGH GROUP OF INSTITUTIONS
BALANA(MOHINDER GARH)123029

Department Of Electronics and Communication Engg.
RPS CET ,Balana(M/Garh)

LIST OF EXPERIMENTS

SR. NO.	NAME OF EXPERIMENT	PAGE NO.
1.	Generation of DSB-SC am signal using balanced modulator	2-6
2.	Generation of SSB-AM signal	7-11
3.	To study envelop detector for demodulation of AM signal and observe diagonal peak clipping effect.	12-14
4.	Frequency modulation using voltage controlled oscillator.	15-19
5.	To study Pulse Amplitude Modulation.	20-21
6.	To study Pulse Position Modulation	22-23
7.	To study Pulse Width Modulation	24-25
8.	Study of ASK modulator and demodulator	26-27
9.	Study of PSK modulator and demodulator	28-29
10.	Study of PSK and QPSK modulator and demodulator	30-31

EXPERIMENT No.1

AIM: - To generate DSB-SC AM signal using balanced modulator.

THEORETICAL CONCEPT:-

A double sideband suppressed carrier signal, or DSBSC, is defined as the modulating signal and the carrier wave.

$$\text{DSBSC} = E \cdot \cos \mu t \cdot \cos \omega t \quad (1)$$

Generally, and in the context of this experiment, it is understood that: $\omega \gg \mu$ (2)

Equation (3) can be expanded to give:

$$\cos \mu t \cdot \cos \omega t = (E/2) \cos(\omega - \mu)t + (E/2) \cos(\omega + \mu)t \quad (3)$$

Equation (3) shows that the product is represented by two new signals, one on the sum frequency $(\omega + \mu)$, and one on the difference frequency $(\omega - \mu)$ - see Figure 1.

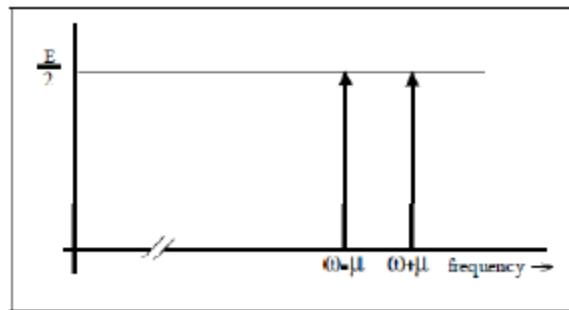

Remembering the inequality of eqn. (2) the two new components are located close to the frequency ω rad/s, one just below, and the other just above it. These are referred to as the lower and upper sidebands respectively.

These two components were derived from a 'carrier' term on ω rad/s, and a message on μ rad/s. Because there is no term at carrier frequency in the product signal it is described as a double sideband suppressed carrier (DSBSC) signal.

The term 'carrier' comes from the context of 'double sideband amplitude modulation' (commonly abbreviated to just AM).

The time domain appearance of a DSBSC (eqn. 1) in a text book is generally as shown in Figure 2.

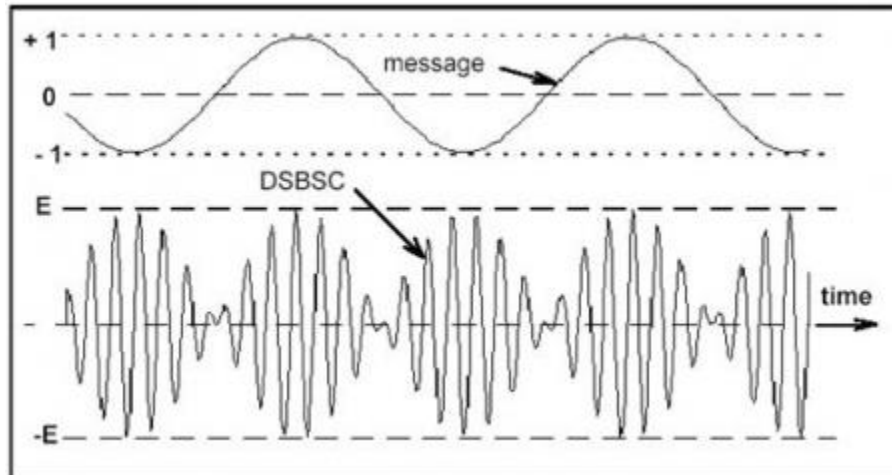

Figure 2: DSBSC seen in time domain

Notice the waveform of the DSBSC in Figure 2, especially near the times when the message amplitude is zero. The fine detail differs from period to period of the message.

This is because the ratio of the two frequencies μ and ω has been made non-integral.

Although the message and the carrier are periodic waveforms (sinusoids), the DSBSC itself need not necessarily be periodic.

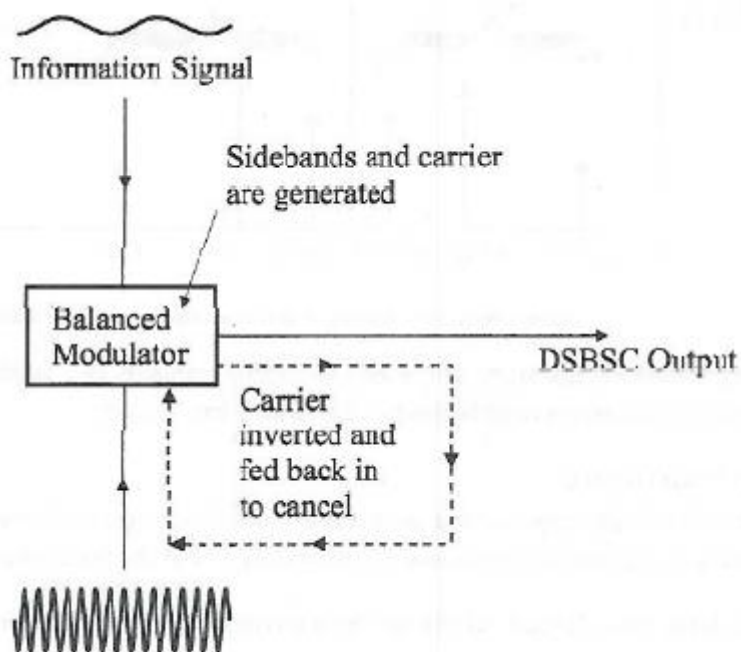

Figure 3: DSBSC Generation using balanced modulator

By removing the carrier from an AM waveforms, the generation of double sideband suppressed carrier (DSBSC) AM is generated.

Properties of DSB-SC Modulation:

- a. There is a 180 phase reversal at the point where $m(t)$ goes negative. This is typical of DSB-SC modulation.
- b. The bandwidth of the DSB-SC signal is double that of the message signal, that is, $BW = 2B$ (Hz).
- c. The modulated signal is centered at the carrier frequency ω_c with two identical sidebands (double-sideband) – the lower sideband (LSB) and the upper sideband (USB). Being identical, they both convey the same message component.
- d. The spectrum contains no isolated carrier. Thus the name suppressed carrier.
- e. (e)The 180 phase reversal causes the positive (or negative) side of the envelope to have a shape different from that of the message signal, see Figure 2.

A balanced modulator has two inputs: a single-frequency carrier and the modulating signal. For the modulator to operate properly, the amplitude of the carrier must be sufficiently greater than the amplitude of the modulating signal (approximately six to seven times greater)

SPECIFICATION OF APPARATUS REQUIRED: - (i) C.R.O. (ii) CRO Probe (iii) DSB/SSB Transmitter (ST2201) and Receiver (ST2202) Trainer (iv)Connecting leads.

PROCEDURE:-

1. Ensure that the following initial conditions exist on the board.
 - a. Audio input select switch in INT position:
 - b. Mode switches in DSB position.
 - c. Output amplifier's gain pot in full clockwise position.
 - d. Speakers switch in OFF position.
2. Turn on power to the ST2201 board.
3. Turn the audio oscillator block's amplitude pot to its full clockwise (MAX) position, and examine the block's output (t.p.14) on an oscilloscope. This is the audio frequency sine wave which will be our modulating signal. Note that the sine wave's frequency can be adjusted from about 300 Hz to approximately 3.4 KHz, by adjusting the audio oscillator's frequency pot meter. Note also that the amplitude of this audio modulating signal can be reduced to zero, by turning the Audio oscillator's amplitude pot meters to its fully counterclockwise (MIN) position. Return the amplitude present to its max position.
4. Turn the balance pot, in the balanced modulator and band pass filter circuit 1 block, to its fully clockwise position. It is this block that we will use to perform double-side band amplitude modulation.

5. Monitor, in turn, the two inputs to the balanced modulator and band pass filter circuits block, at t.p.1 and t.p.9. Note that:
 - a. The signal at t.p.1 is the audio-frequency sine wave from the audio oscillator block. This is the modulating input to our double-sideband modulator.
 - b. Test point 9 carries a sine wave of 1MHz frequency and amplitude 120mVpp approx. This is the carrier input to our double-sideband modulator.
6. Next, examine the output of the balanced modulator and band pass filter circuit 1 block (at t.p.3), together with the modulating signal at t.p.1. Trigger the oscilloscope on the t.p.1 signal. The output from the balanced modulator and band pass filter circuit 1 block (at t.p. 3) is a DSBFC AM waveform, which has been formed by amplitude-modulating the 1MHz carrier sine wave with the audio-frequency sine wave from the audio oscillator.

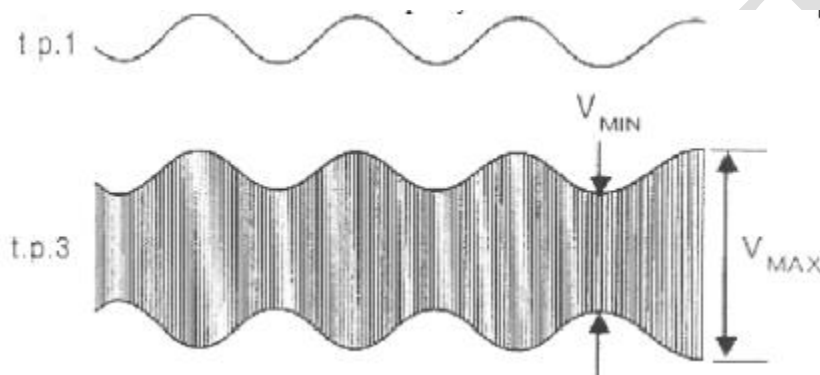

Figure 4: DSB FC (AM) waveforms

7. Now vary the amplitude and frequency of the audio-frequency sine wave, by adjusting the amplitude and frequency present in the audio oscillator block. Note the effect that varying each pot has on the amplitude modulated waveform. The amplitude and frequency amplitudes of the two sidebands can be reduced to zero by reducing the amplitude of the modulating audio signal to zero. Do this by turning the amplitude pot to its MIN position, and note that the signal at t.p.3 becomes an un-modulated sine wave of frequency 1 MHz, indicating that only the carrier component now remains. Return the amplitude pot to its maximum position.

Now turn the balance pot in the balanced modulator and band pass filter circuit 1 block, until the signal at t.p. 3 is as shown in Fig. 5

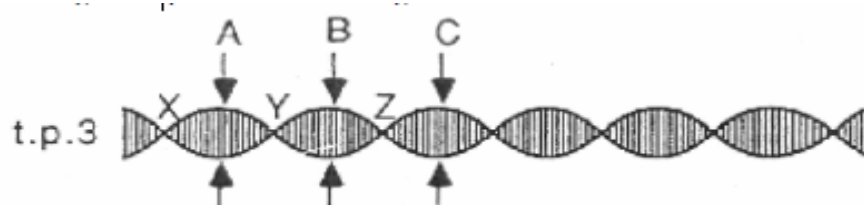

Figure 5: Output of BPF

The balance pot varies the amount of the 1 MHz carrier component, which is passed from the modulator's output. By adjusting the pot until the peaks of the waveform (A, B, C and so on) have the same amplitude, we are removing the carrier component altogether. We say that the carrier has been 'balanced out' (or 'suppressed') to leave only the two sidebands.

The waveform at t.p.3 is known as a double-side suppressed carrier (DSBSC) waveform, and its frequency spectrum is as shown in Fig.1. Note that now only the two sidebands remain, the carrier component has been removed.

8. Change the amplitude and frequency of the modulating audio signal (by adjusting the audio oscillator block's amplitude and frequency pots), and note the effect that these changes on the DSBSC waveform. The amplitudes of the two sidebands can be reduced to zero by reducing the amplitude of the modulating audio signal to zero. Do these by turning the amplitude present to its MIN position, and note that the monitored signal becomes a D C level, indicating that there .are now no frequency components present.

Return the amplitude pot to its MAX position.

9. Examine the output from the output amplifier block (t.p.13), together with the audio modulating signal (at t.p.1), triggering the scope with the audio modulating signal. Note that the DSBSC waveform appears, amplified slightly at t.p.13, as we will see later, it is the output amplifier's output signal which will be transmitted to the receiver.
10. By using the microphone, the human voice can be used as the modulating signal, instead of using ST2201's audio oscillator block. Connect the module's output to the external audio input on the ST2201 board, and put the audio input select switch in the ext position. The input signal to the audio input module may be taken from an external microphone or from a cassette recorder, by choosing the appropriate switch setting on the module.

PRECAUTIONS:-

1. Do not use open ended wires for connecting to 230 V power supply.
2. Before connecting the power supply plug into socket, ensure power supply should be switched off
3. Ensure all connections should be tight before switching on the power supply.
4. Take the reading carefully.
5. Power supply should be switched off after completion of experiment.

OBSERVATION DATA:

Draw wave forms as observed on CRO and label the different waveforms appropriately.

RESULT AND COMMENTS:-

The DSBSC signal has been generated using balanced modulator.

APPLICATIONS:

- a. Analogue TV systems: to transmit color information.
- b. One important application of DSB is the transmission of color information in a TV signal.
- c. DSB-SC is a technique used in electronic communication, most commonly for transmitting information via a radio carrier wave.

ECE DEPTT.

EXPERIMENT NO.2

AIM: - To generate SSB-AM signal.

THEORETICAL CONCEPT:-

Single sideband suppressed carrier (SSB-SC) modulation was the basis for all long distance telephone communications up until the last decade. It was called "L carrier". It consisted of groups of telephone conversations modulated on upper and/or lower sidebands of contiguous suppressed carrier. The groups and sideband orientations (USB, LSB) supported hundreds and thousands of individual telephone conversations.

SSB Transmitter:

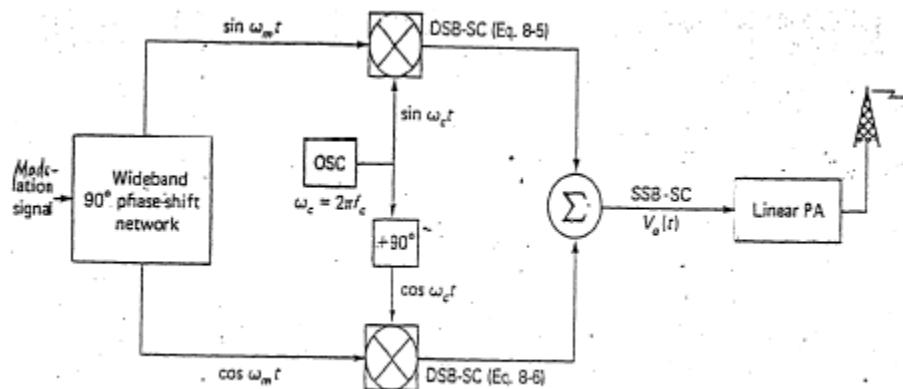

A double sideband transmission was the first method of modulation developed and for broadcast stations, is still the most popular in medium and long range broadcast stations. The reason for such wide spread is that the receiver design can be simple and reliable. Radio is also used for the communication in which the signal is addressed to the receiving station or group of stations. For this type of communication other systems are used, one of which is investigated.

SPECIFICATION OF APPARATUS USED: (i) C.R.O. (ii) CRO Probe (iii) DSB/SSB Transmitter (ST2201) and Receiver (ST2202) Trainer (iv) Connecting leads.

PROCEDURE:-

1. Ensure that the following initial conditions exist on the board.
 - a. Audio input select switch in INT position:
 - b. Mode switches in DSB position.
 - c. Output amplifier's gain pot in full clockwise position.
 - d. Speakers switch in OFF position.
2. Turn on power to the ST2201 board.

3. Turn the audio oscillator block's amplitude pot to its fully clockwise (MAX) position, and examine the block's output (t.p.14) on an oscilloscope. This is the audio frequency sine wave which will be used as out modulating signal. Note that the sine wave's frequency can be adjusted from about 300Hz to approximately 3.4 KHz, by adjusting the audio oscillator's frequency pot.
4. To achieve signal- sideband amplitude modulation, we will utilize the following three blocks on the **ST2201** module.
 - a. Balanced modulator.
 - b. Ceramic band pass filter
 - c. Balanced modulator and band pass filter circuit 2.
 We will now examine the operation of each of these blocks in detail.
5. Monitor the two inputs to the balanced modulator block, at t.p.15 and t.p.6 noting that:
 - a. The signal t.p. 15 is the audio frequency sine wave from the audio oscillator block.
 - b. This is the modulating input to the balanced modulator block.
 - c. The signal at t.p. 6 is a sine wave whose frequency is slightly less than 455 KHz. It is by the 455 KHz oscillator block, and is the carrier input to the balanced modulator block.
6. Next, examine the output of the balanced modulator block (at t.p.17), together with the modulating signal at t.p.15 trigger the oscilloscope on the modulating signal. Check that the waveforms are as shown Fig. 2.

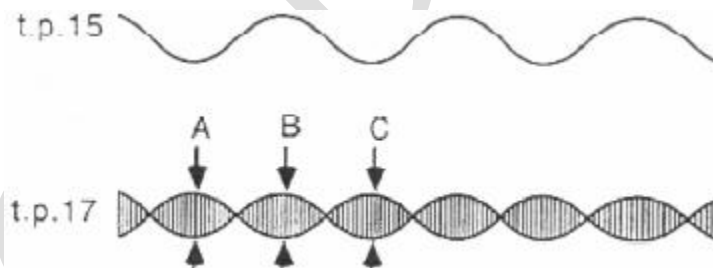

Figure 2: Modulating and Modulated Signal waveform

Note that it may be necessary to adjust the balanced modulator block's balance pot, in order to ensure that the peaks of t.p.17's waveform envelope (labeled A, B, C etc. in the above diagram) all have equal amplitude. The frequency spectrum of this DSBSC waveform is shown in Fig.3.

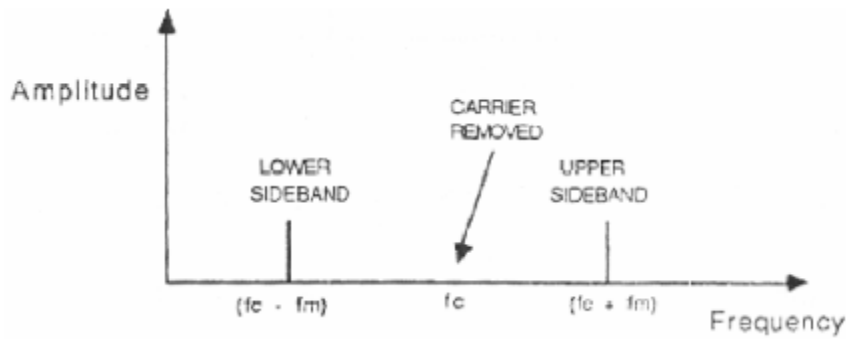

Figure 3: DSBSC Sidebands

7. The DSBSC output from the balanced modulator block is next passed on to the ceramic filter block, whose purpose is to pass the upper sideband, but block the lower sideband. It was mentioned earlier that the frequency of the carrier to the balanced modulator block has been arranged to be slightly less than 455 KHz.

In fact, the carrier chosen so that, whatever the modulating frequency f_m , the upper sideband (at $f_c + f_m$) will fall inside the filter's pass band, while the lower sideband (at $f_c - f_m$) always falls outside. Consequently, the upper sideband will suffer little attenuation, while the lower sideband will be heavily attenuated to such an extent that it can be ignored. This is shown in the frequency

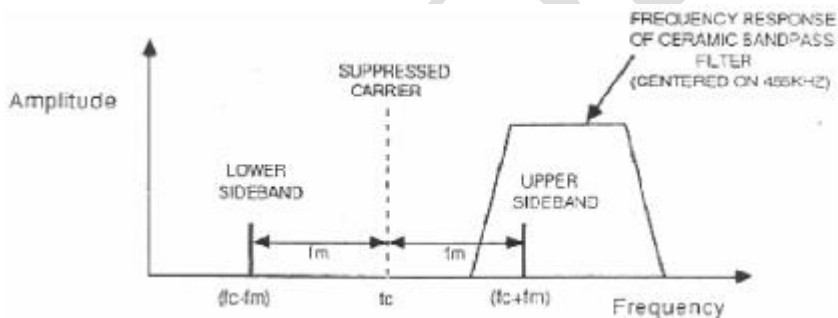

Figure 4: Frequency Response of Ceramic BPF

8. Monitor the output of the ceramic band pass filter block (at t.p. 20) together with the audio modulating signal (at t.p.15) using the later signal to trigger the oscilloscope.

Note that the envelope of the signal at t.p. 20 now has fairly constant amplitude, as shown in Fig.5.

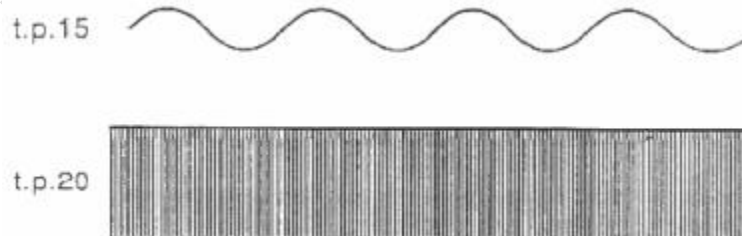

Figure 5: Input Audio Signal and SSB output Signal

If the amplitude of the signal at t.p. 20 is not reasonably constant, adjust the balance pot in the balance modulator block to minimize variations in the signal's amplitude. If the constant-amplitude waveform still cannot be obtained, then the frequency of the 455KHz oscillator needs to be trimmed.

9. Now, trigger the oscilloscope with the ceramic band pass filter's output signal (t.p.20) and note that the signal is a good, clean sine wave, indicating that the filter has passed the upper sideband only.

Next, turn the audio oscillator block's frequency pot throughout its range. Note that for most audio frequencies, the waveform is a good, clean sine wave, indicating that the lower sideband has been totally rejected by the filter.

10. Note that there is some variation in the amplitude of the signal at the filter's output (t.p. 20) as the modulating frequency changes.
11. Note that, by passing only the upper side band of frequency (f_c+f_m), all we have actually done is to shift out audio modulating signal of frequency f_m up in frequency by an amount equal to the carrier frequency f_c . This is shown in Fig.7.

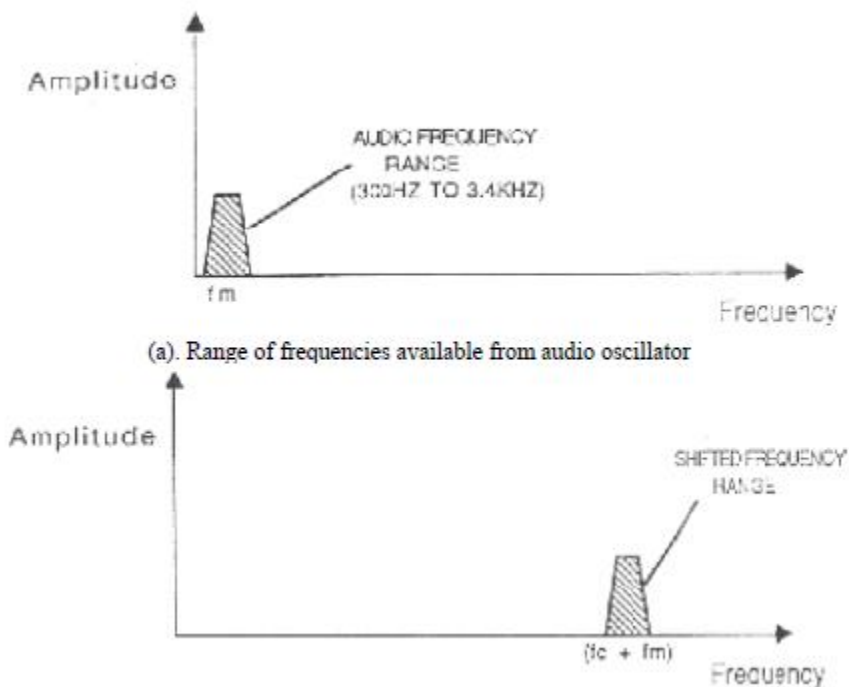

(a). Range of frequencies available from audio oscillator
 (b). Corresponding range of output frequencies from ceramic band pass filter block
 Figure 7: Range of frequency output from audio oscillator and ceramic BPF

12. With the audio oscillator block's frequency pot roughly in its midway position, turn the block's amplitude pot to its MIN position, and note that the amplitude of the signal at the ceramic band pass filter's output (t.p. 20) drops to zero. This highlights

one on the main advantages of SSB amplitude modulation if there is no modulating signal, then the amplitude of the SSB waveform drops to zero, so that no power is wasted. Return the amplitude pot to its MAX position.

13. Now examine the output of the balanced modulator and band pass filter circuit 2 blocks (t.p.22), and check that the waveform is a good sine wave of frequency approximately 1.45MHz. This indicates that only the upper sideband is being passed by the block. Check that the waveform is reasonably good sinusoid for all audio modulating frequencies (i.e. all positions of the audio oscillator's frequency pot
14. Examine the final SSB output (at t.p. 22) together with the output from the output amplifier block (t.p. 13). Note that the final SSB waveform appears, amplified slightly, at t.p. 13.
15. By using the microphone the human voice can be used as the audio modulating signal, instead of using ST2201's audio oscillator block. Connect the microphone to the external audio input on the ST2201 board, and put the audio input select switch in the EXT position.

PRECAUTIONS:-

1. Do not use open ended wires for connecting to 230 V power supply.
2. Before connecting the power supply plug into socket, ensure power supply should be switched off
3. Ensure all connections should be tight before switching on the power supply.
4. Take the reading carefully.
5. Power supply should be switched off after completion of experiment.

RESULT AND COMMENTS:-

The SSB signal has been generated using balanced modulator.

EXPERIMENT No.3

AIM: - To generate Frequency modulated signal using Voltage Control Oscillator.

THEORETICAL CONCEPT:-

Frequency modulation is a form of angle modulation in which the amplitude of the modulated carrier is kept constant while its frequency and its rate of change are varied by the modulating signal. In FM the instantaneous angular frequency ω_i is varied linearly in accordance with the instantaneous magnitude of base band signal $X(t)$, about an unmodulated carrier frequency (also called as resting frequency) ω_c and the rate at which the carrier shifts from its resting point to its non resting point is determined by the frequency of modulating signal while keeping the amplitude of the carrier wave constant.

$$\text{Carrier signal } C(t) = A \sin(\omega_c t + \theta_0) = A \sin \Phi \dots\dots\dots (1)$$

where ω_c is the frequency of Carrier wave in radians/second and

$$\Phi \text{ in radians} = \text{Total phase angle of the unmodulated carrier} = (\omega_c t + \theta_0) \dots\dots (2)$$

In FM while the amplitude A remains constant, instantaneous value of Φ changes.

If $\omega_i(t)$ = Instantaneous value of angular velocity and Φ_i = Instantaneous phase angle of FM wave,

$$\text{then, } \omega_i(t) = d\Phi_i / dt \dots\dots\dots (3)$$

$$\Phi_i = \int \omega_i(t) dt \dots\dots\dots (4)$$

Therefore FM wave can be represented as $S(t) = A \sin \Phi_i \dots\dots\dots (5)$

$$\text{Modulating voltage Signal} = X(t) \text{ volts } \dots\dots\dots (6)$$

Then instantaneous angular frequency of an FM signal is given by

$$d\Phi_i / dt = \omega_i(t) = \omega_c + K_f X(t) \dots\dots\dots (7)$$

where K_f = Constant of proportionality = frequency sensitivity of the modulator in

Hertz per volt

$$\text{Therefore Frequency variation} = |K_f X(t)| \dots\dots\dots (8)$$

Since the value of ω_c is assumed to be fixed,

$$\Phi_i = \int \omega_i(t) dt = \int [\omega_c + K_f X(t)] dt = \omega_c t + K_f \int X(t) dt \dots\dots\dots (9)$$

Frequency Deviation: It is the amount by which carrier frequency is varied from its unmodulated value and it is same as frequency variation.

$$\text{Max Frequency deviation } \Delta W = |K_f X(t)| \text{ max} \dots\dots\dots (10)$$

Very often we write $\Delta W = \delta$;

Maximum allowed deviation = 75 kHz

Frequency Modulation Index mf: It is the ratio of frequency deviation ΔW in rad/sec to the angular frequency of modulating signal W_m or frequency deviation in Hertz/sec to the modulating frequency in Hertz/sec.

$$\text{Thus } mf = \Delta W / W_m = \delta / W_m \text{ if } \delta \text{ is given in rad /Sec (11)}$$

$$\text{If } \delta \text{ is given in Hertz/Sec then } mf = \delta / f_m \text{ (12)}$$

EXPERIMENTAL SETUP:-

The audio oscillator supplies the information signal and could, if we wish, be replaced by a microphone and AF amplifier to provide speech and music instead of the sine wave signals that we are using with **ST2203**.

The FM modulator is used to combine the carrier wave and the information signal in much the same way as in the AM transmitter. The only difference in this case is that the generation of the carrier wave and the modulation process is carried out in the same block. It is not necessary to have the two processes in same block, but in our case, it is. The output amplifier increases the power in the signal before it is applied to the antenna for transmission just as it did in the corresponding block in the FM transmitter.

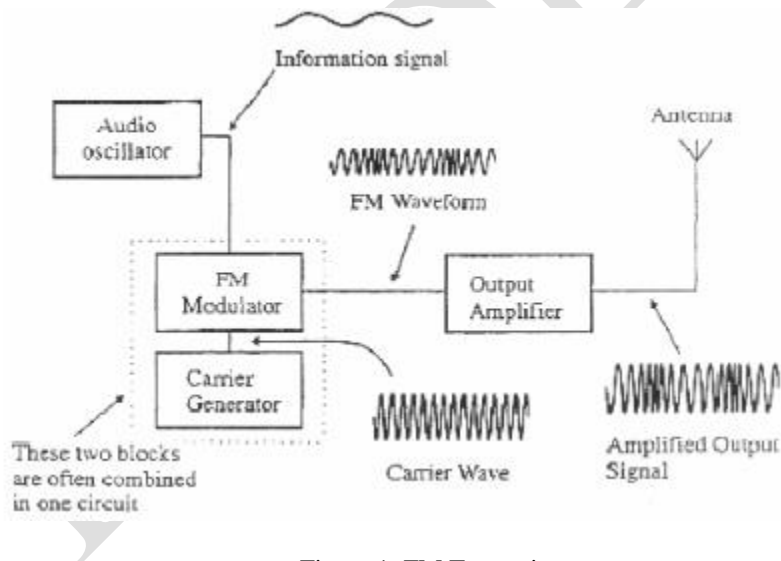

Figure 1: FM Transmitter

Controlling the VCO:

To see how the VCO is actually controlled, let us assume that it is running at the same frequency as an un-modulated input signal. The input signal is converted into a square wave and, together with the VCO output, forms the two inputs to an Exclusive – OR gate. Remember that the Exclusive - OR gate provides an output whenever the two inputs are different in value and zero output whenever they are the same. The provided an output from the Exclusive -OR gate with an on-off ratio of unity and an average voltage at the output of half of the peak value. Now let us assume that the FM signal at the input

decreases in frequency (see fig. 34). The period of the 'squared up' FM signal increases and the mean voltage level from the Exclusive -OR gate decreases. The mean voltage level is both the demodulated output and the control voltage for the VCO. The VCO frequency will decrease until its frequency matches the incoming FM signal.

SPECIFICATION OF APPARATUS USED: - (i) C.R.O. (ii) CRO Probe (ii) FM Modulation and Demodulation Trainer (ST 2203) (iv) Connecting leads.

PROCEDURE:--

1. Ensure that the following initial conditions exist on the **ST2202** board.
 - a. All switched faults off.
 - b. Amplitude pot (in mixer amplifier block) in fully clockwise position.
 - c. VCO switch in 'ON' position.
2. Turn the audio oscillator block's amplitude pot to its fully clockwise position, and examine the block's output t.p.1 on an oscilloscope. This is the audio frequency sine wave, which will be used as our modulating signal. Note that the sine wave's frequency can be adjusted from about 300Hz to approximately 3.4 KHz, by adjusting the audio oscillator's frequency pot.
3. Connect the output of audio oscillator to VCO section's MOD In socket.
4. Turn ON the power supply.
5. Observe the modulating signal and modulated output at the VCO's MOD OUT socket by using CRO.
6. Calculate $m_f = \delta / f_m$.
7. Vary the modulating frequency keeping carrier freq constant and repeat steps 3 and 4.
8. Vary the carrier frequency keeping modulator freq constant and repeat steps 3 and 4.
9. Tabulate the results.

PRECAUTIONS:-

1. Do not use open ended wires for connecting to 230 V power supply.
2. Before connecting the power supply plug into socket, ensure power supply should be switched off.
3. Ensure all connections should be tight before switching on the power supply.
4. Take the reading carefully.
5. Power supply should be switched off after completion of experiment.

OBSERVATION DATA:-

Sno.	Modulating frequency(Hz)	Carrier frequency(KHz)	Modulation Index(m_f)
1.			
2.			
3.			

SAMPLE CALCULATION:-

$$\begin{aligned} m_f &= \delta / f_m \\ &= 2 \times 8.3 \times 10^3 / 1000 \\ &= 16.6 \end{aligned}$$

RESULT AND COMMENTS:-

Frequency modulated wave using VCO is obtained on CRO and m_f is calculated.

EXPERIMENT NO: 4

AIM: - To study envelope detector for AM signal and observe peak diagonal clipping effect.

THEORETICAL CONCEPT:-

The AM Transmitter:

The transmitter circuits produce the amplitude modulated signals which are used to carry information over the transmission to the receiver. The main parts of the transmitter are shown in Fig.11. In Fig.11 and 12, we can see that the peak-to-peak voltage in the AM waveform increase and decrease in sympathy with the audio signal.

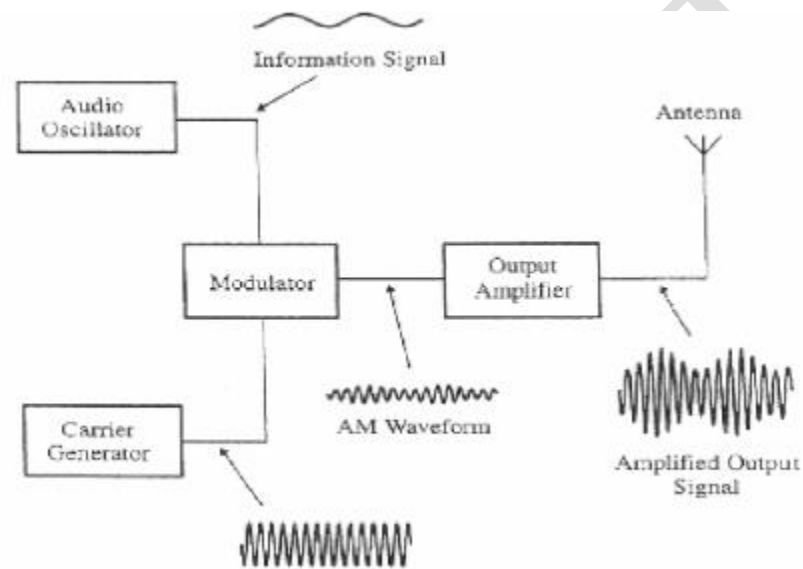

Fig. 1: AM Transmitter System

To emphasize the connection between the information and the final waveform, a line is sometimes drawn to follow the peaks of the carrier wave as shown in Fig.12. This shape, enclosed by a dashed line in our diagram, is referred to as an 'envelope', or a 'modulation envelope'. It is important to appreciate that it is only a guide to emphasize of the AM waveform.

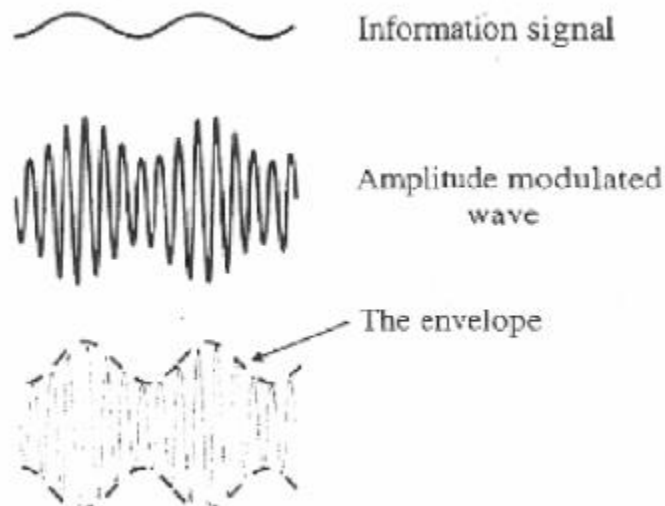

Figure 2: Waveforms in AM transmitter

AM Reception: The EM waves from the transmitting antenna will travel to the receiving antenna carrying the information with it. The stages of AM reception are shown in Fig.3.

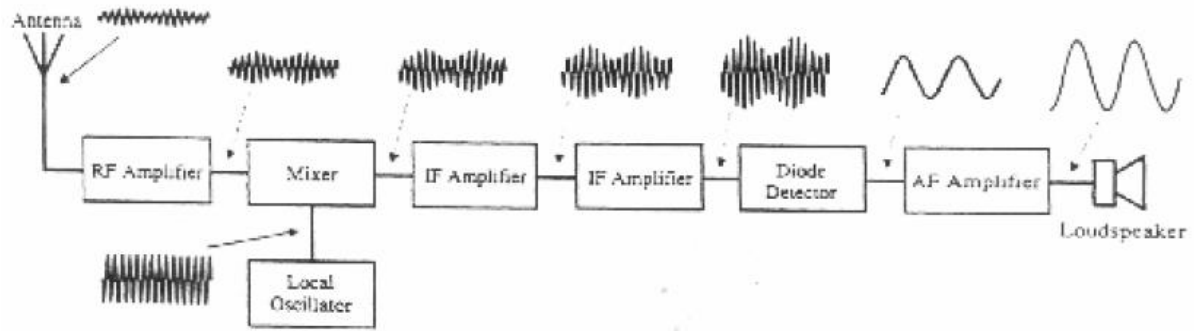

Figure 3: AM Reception

Envelope Detector:

The simplest form of envelope detector is diode detector. The function of the diode detector is to extract the audio signal from the signal at the output of the IF amplifiers. It performs this task in a very similar way to a half wave rectifier converting an AC input to a DC output. Fig.4 shows a simple circuit diagram of the diode detector.

EXPERIMENTAL SETUP:

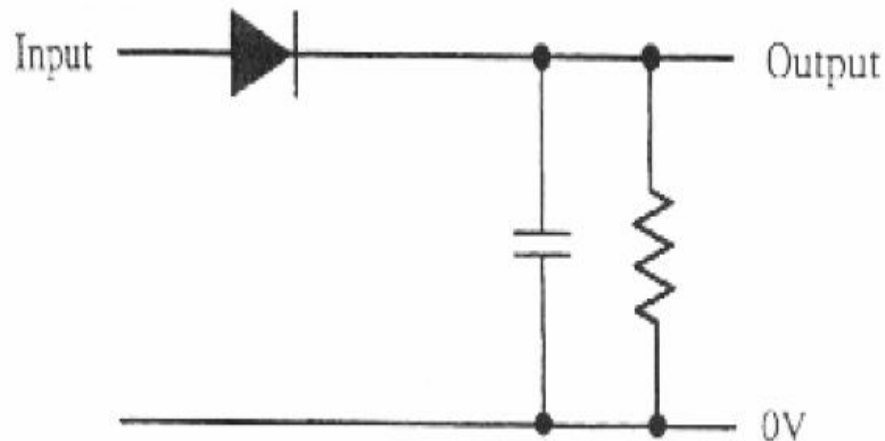

Figure 4: Diode Detector

At the input to the audio amplifier, a low pass filter is used to remove the IF ripple and a capacitor blocks the DC voltage level. The remaining audio signals are then amplified to provide the final output to the loudspeaker.

SPECIFICATION OF APPARATUS USED: (i) C.R.O. (ii) CRO Probe (iii) DSB/SSB Transmitter (ST 2201) and Receiver Trainer (ST 2202) (iv) Connecting leads.

PROCEDURE:-

1. Position the **ST2201** and **ST2202** modules, with the **ST2201** board on the left, and a gap of about three inches between them.
2. Ensure that the following initial conditions exist on the **ST2201** board.
 - a. Audio oscillator's amplitude pot in fully clockwise position.
 - b. Audio input select switch in INT position.
 - c. Balance pot in balanced modulator and band pass filter circuit 1 block, in full clockwise position;
 - d. Mode switches in DSB position.
 - e. Output amplifier's gain pot in full counter-clockwise position.
 - f. TX output select switch in ANT position:
 - g. Audio amplifier's volume pot in fully counter-clockwise position.
 - h. Speakers switch in ON position.
 - i. On-board antenna in vertical position, and fully extended.
3. Ensure that the following initial conditions exist on the **ST2102** board:
 - a. RX input select switch in ANT position.
 - b. R.F. amplifier's tuned circuit select switch in INT position.
 - c. R.E amplifier's gain pot in fully clock-wise position;
 - d. AGC switch in INT position.
 - e. Detector switch in diode position.
 - f. Audio amplifier's volume pot in fully counter-clockwise position.
 - g. Speakers switch in ON position.
 - h. Beat frequency oscillator switch in OFF position.
 - i. On-board antenna in vertical position, and fully extended.
4. Turn ON power to the modules.
5. On the **ST2202** module, slowly turn the audio amplifier's volume pot clockwise, until sounds can be heard from the on-board loudspeaker. Next, turn the vernier tuning dial until a broad cast station can be heard clearly, and adjust the volume control to a comfortable level.
6. The first stage or 'front end' of the **ST2202** AM receiver is the R.F amplifier stage.

This is a wide -bandwidth tuned amplifier stage, which is tuned into the wanted station by means of the tuning dial. Once it has been tuned into the wanted station, the R.F. amplifier, having little selectivity, will not only amplify, but also those frequencies that are close to the wanted frequency. As we will see later, these nearby frequencies will be removed by subsequent stages of the receiver, to leave only the wanted signal. Examine the envelope of the signal at the R.F. amplifier's output, with an a.c. - coupled oscilloscope channel.

7. The next stage of the receiver is the mixer stage, which mixes the R.F. amplifier's output with the output of a local oscillator. The Frequency of the local oscillator is also tuned by means of the tuning dial, and is arranged so that its frequency is always 455 KHz above the signal frequency that the R.F. amplifier is tuned to.
8. The operation of the mixer stage is basically to shift the wanted signal down to the IF frequency, irrespective of the position of the tuning dial.

The end result of this process is that the carrier frequency of the selected AM station is shifted down to 455 KHz (the IF Frequency), and the sidebands of the AM signal are now either side of 455 KHz.

10. Tune in to a strong broadcast station again and note that the monitored signal shows little, if any, sign of modulation. This is because the wanted component, which is now at the IF frequency of 455 KHz, is still very small in component, which is now at the IF frequency of 455 KHz, is still very small in comparison to the local oscillator component. What we need to do now is to preferentially amplify frequencies around 455 KHz, without amplifying the higher-frequency local oscillator and SUM components.
11. Examine the output of IF amplifier 2 with an a.c.-coupled oscilloscope channel, noting that the amplitude of the signal has been further amplified by this second IF amplifier stage. IF amplifier 2 has once again preferentially amplified signals around the IF frequency (455 KHz), the resulting signal at the output of IF amplifier 2 (t.p.28) is therefore composed almost entirely of a 455 KHz carrier, and the A.M. sidebands either side of it carrying the wanted audio information.
12. The next step is extract this audio information from the amplitude variations of the signal at the output of IF amplifier 2. This operation is performed by the diode detector block, whose output follows the changes in the amplitude of the signal at its input.
13. The final stage of the receiver is the audio amplifier block contains a simple lowpass filter which passes only audio frequencies, and removes the high frequency ripple from the diode detector's output signal. This filtered audio signal is applied to the input of an audio power amplifier, which drives on board loudspeaker (and the headphones, if these are used).

The final result is the sound you are listening to the audio signal which drives the loudspeaker can be monitored at t.p. 39 (providing that the audio amplifier block's volume pot is not in its minimum volume position). Compare this signal with that at the diode detector's output (t.p. 31), and note how the audio amplifier block's low pass filter has 'cleaned up' the audio signal.

You may notice that the output from the audio amplifier block (t.p. 39) is inverted with respect to the signal at the output of the diode detector (t.p. 31) this inversion is performed by the audio power amplifier IC, and in no way affects the sound produced by the receiver.

- 14.** Now that we have examined the basic principles of operation of the **ST2202** receiver for the reception and demodulation of AM broadcast signals, we will try receiving the AM signal from the **ST2201** transmitter. Presently, the gain of **ST2201**'s output amplifier block is zero, so that there is no output from the Transmitter.

Now turn the gain pot in **ST2201**'s output amplifier block to its fully clockwise (maximum gain) position, so that the transmitter generates an AM signal. On the **ST2201** module, examine the transmitter's output signal (t.p.13), together with the audio modulating signal (t.p.1), triggering the 'scope with the signal'. Since **ST2201** TX output select switch is in the ANT position, the AM signal at t.p.13 is fed to the transmitter's antenna.

Prove this by touching **ST2201**'s antenna, and nothing that the loading caused by your hand reduces the amplitude of the AM waveform. at t.p.13. The antenna will propagate this AM signal over a maximum distance of about 1.4 feet. We will now attempt to receive the propagated AM waveform with the **ST2201/ ST2202** board, by using the receiver's on board antenna.

- 15.** On the **ST2201** module, turn the volume pot (in the audio amplifier block) clockwise, until you can hear the tone of the audio oscillator's output signal, from the loudspeaker on the board.
- 16.** On the **ST2201/ST2202** receiver, adjust the volume pot so that the receiver's output can be clearly heard. Then adjust the receiver's tuning dial until the tone generated at the transmitter is also clearly audible at the receiver. Check that you are tuned into the transmitter's output signal, by varying **ST2201**'s frequency pot in the audio oscillator block, and nothing that the tone generated by the receiver changes.

The **ST2201/2202** receiver is now tuned into AM signal generated by the **ST2201** transmitter. Briefly check that the waveforms, at the outputs of the following receiver blocks, are as expected:

R. F. Amplifier (t.p.12)

Mixer (t.p.20)

I.F. Amplifier 1 (t.p.24)

I.F. Amplifier 2 (t.p.28)

Diode Detector (t.p.31)

Audio Amplifier (t.p.39)

- 17.** By using the microphone, the human voice can be used as transmitter's audio modulating signal, instead of using **ST2201**'s audio oscillator block. Use DSB and not DSBSC. Connect the microphone's output to the external audio input on the **ST2201** board, and put the audio input select switch in the EXT position.

18. In the output of diode detector peak diagonal clipping can be observed at low values of time constant of tuning circuitry.

PRECAUTIONS:-

1. Do not use open ended wires for connecting 230 V power supply.
2. Before connecting the power supply plug into socket, ensure power supply should be switched off.
3. Ensure all connections should be tight before switching on the power supply.
4. Take the reading carefully
5. Power supply should be switched off after completion of experiment

RESULT AND COMMENTS:-

AM signal has been demodulated using envelope detector and peak diagonal clipping effect has been observed.

EXPERIMENT No.5

AIM:-To study Pulse Amplitude Modulation.

THEORETICAL CONCEPT:-

Pulse Modulation: We know that in Analog modulation systems, some parameter of a sinusoidal carrier (continuous in time domain) is varied according to the instantaneous value of the modulating signal. But in pulse modulation methods, the carrier is no longer a continuous signal but consists of a train of uniform pulses having a defined PRF (Pulse Repetition Frequency).

The continuous modulating message signal waveforms are sampled at regular intervals. Information regarding the signal is transmitted only at the sampling times, together with any synchronizing pulses that may be required. At the receiving end, the original wave form may be reconstituted with negligible distortion from the information regarding the samples, if these samples are taken with minimum sufficient frequency.

In Pulse Modulation some parameter of the pulsed carrier is varied according to the instantaneous value of the modulating signal. Pulse modulation may be broadly subdivided into two categories: Analog and Digital. In the former, the indication of sample amplitude may be infinitely variable, while in the latter a code which indicates the sample amplitude to the nearest pre-determined level is sent.

Pulse-Amplitude and Pulse-Time Modulation are both analog while the Pulse-code and Delta modulation are both digital.

All the modulation systems have sampling in common, but they differ from each other in the manner of indicating the sample amplitude. In PAM the signal is sampled at a regular intervals and each sample is made proportional to the instant of sampling. In single polarity PAM is fixed, AC level is acted to ensure that all the pulse are +Ve going. The frequency spectrum is decaying but with decaying amplitude. The rate of decay depends upon the width of the pulses. As the pulses are made wider, the spectrum decays faster.

EXPERIMENTAL SETUP:

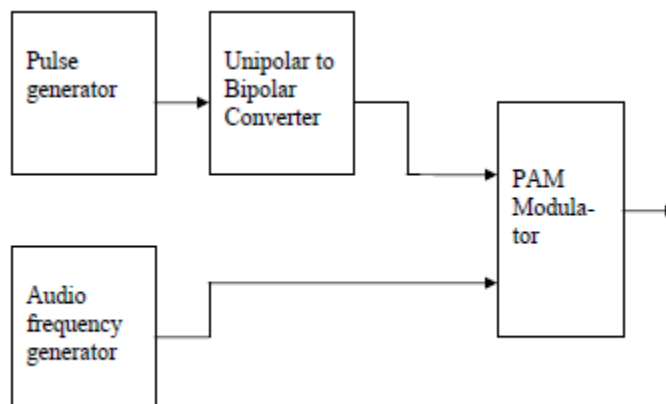

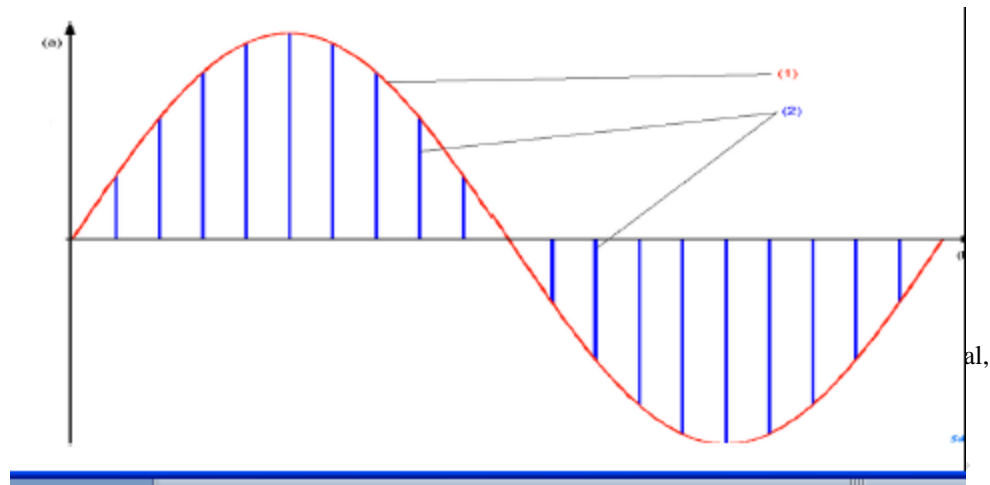
WAVEFORM FORMS :-

SPECIFICATION OF APPARATUS USED:-CRO, experimental kit, power supply, connecting leads.

PROCEDURE:-

1. Make the connection according to the block diagram.
2. Connect pulse generator to the unipolar to bipolar converter Pulse generator
3. Connect the audio frequency of 2 KHz, 2V to modulator.
4. Connect the modulator output to CRO.
5. Observe output on CRO.

PRECAUTIONS:-

1. Do not use open ended wires for connecting to 230 V power supply.
2. Before connecting the power supply plug into socket, ensure power supply should be switched off.
3. Ensure all connections should be tight before switching on the power supply.
4. Take the reading carefully.
5. Power supply should be switched off after completion of experiment

RESULT AND COMMENTS:-

Pulse modulated waveform is obtained on CRO.

EXPERIMENT NO: 6

AIM: - To study the pulse width modulation.

THEORETICAL CONCEPT:-

PWM is a part of PTM modulation. The PWM is also called PDM (pulse duration modulation) and sometimes it is also called PLM (pulse length modulation).

In PWM width of each pulse depends on the instantaneous value of the base band signal at the sampling instant. In pulse width modulation continuous waveform is sampled at regular intervals and the width of each pulse is kept proportional to the magnitude of signal at that instant in PWM. In this pulse is varied accordance with the modulating signal but the amplitude and starting time of each pulse is fixed .In PWM, the information about the base band signal lies in the trailing edge of the pulse

PWM has the disadvantage, when compared with PPM that its pulses are of varying width and therefore of varying power content .This means that transmitter must be powerful enough to handle the maximum- width pulses, although the average power transmitted is perhaps only half of the peak power.

PWM still works if synchronization between transmitter and receiver fails.

Generation and Demodulation of PWM

PWM may be generated by applying trigger pulses to control the duration of these pulses. The emitter coupled mono-stable multi-vibrator is used as voltage to time converter, since its gate width is dependent on the voltage to which the capacitor C is charged .If this voltage is varied in accordance with a signal voltage, a series of rectangular pulses will be obtained, with widths varying as required.

The demodulation of pulse width modulation is a simple process. PWM is fed to an integrating circuit from which a signal emerges whose amplitude at any time is proportional to the pulse width at that time.

EXPERIMENTAL SETUP:

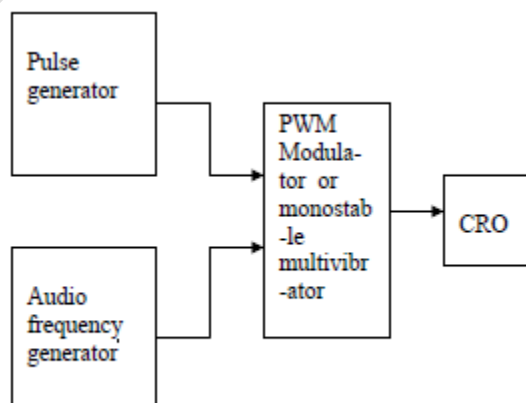

SPECIFICATION OF APPARATUS USED:-CRO, experimental kit, power supply, connecting leads.

PROCEDURE:-

1. Make the connection according to the block diagram.
2. Connect the audio frequency of 2 KHz, 2V to modulator.
3. Connect the modulator output to CRO.
4. Switch ON the power supply.
5. Observe output on CRO.

PRECAUTIONS:-

1. Do not use open ended wires for connecting to 230 V power supply.
2. Before connecting the power supply plug into socket, ensure power supply should be switched off
3. Ensure all connections should be tight before switching on the power supply.
4. Take the reading carefully.
5. Power supply should be switched off after completion of experiment.

OBSERVATION DATA:

Clock								
Data								
Data	0	1	2	4	0	4	1	0

RESULT AND COMMENTS:-

Pulses width modulated wave is obtained on CRO.

ECE DEPTT.

EXPERIMENT No.7

AIM:--To study the Pulse Position Modulation.

THEORETICAL CONCEPT:-

In pulse position modulating the amplitude of pulse is kept constant and position of the pulse in relation to the position of the reference pulse or synchronize pulse is varied by each sample value of modulating signal.

PPM may be obtained from PWM. In PWM each pulse has a leading edge and a trailing edge but the location of leading edge are fixed where trailing edge are depends on the pulse width. Thus PPM may be obtained from PWM by simply getting side of the leading edge and slots tops of PWM pulses.

In pulse position modulating the amplitude of pulse is kept constant and position of the pulse in relation to the position of the reference pulse or synchronize pulse is varied by each sample value of modulating signal.

In PWM each pulse has a leading edge and a trailing edge but the location of leading edge are fixed where trailing edge are depends on the pulse width. The trailing edges of PWM pulses are in fact position modulated. Thus PPM may be obtained from PWM by simply getting rid of the leading edge and slots tops of PWM pulses. In comparison with PWM, PPM has the advantage of requiring constant transmitter power output, but the disadvantage of depending on transmitter –receiver synchronization.

Generation and demodulation of PPM:

PPM may be generated from PWM easily. First of all, PWM pulses are generated and then they are differentiated. The result is another pulse train which has positive going narrow pulses corresponding to leading edges and negative going narrow pulses corresponding to trailing edges. If the position corresponding to the trailing edges of an un-modulated PWM pulse is counted as zero displacement, then the trailing edges of a modulated pulse will arrive earlier or later. An unmodulated PWM pulse is one that is obtained when the instantaneous signal value is zero.

The differentiated pulses corresponding to the leading edges are removed with a diode clipper and the remaining pulses are nothing but position modulated output.

When the PPM is demodulated in the receiver, it is again first converted into PWM by using flip-flop or bistable multivibrator. One input of the multivibrator receives trigger pulses from a local generator which is synchronized by trigger pulses received from the transmitter, and these triggers are used to switch off one of the stages of the flip-flop. The PPM pulses are fed to the other base of the flip-flop and switch that stage ON. The period of time during which this particular stage is OFF, depends on the time difference between the two triggers, so that the resulting pulse has a width that depends on the time

displacement of each individual PPM pulse. The PWM pulse train thus obtained is a demodulated output.

EXPERIMENTAL SETUP:

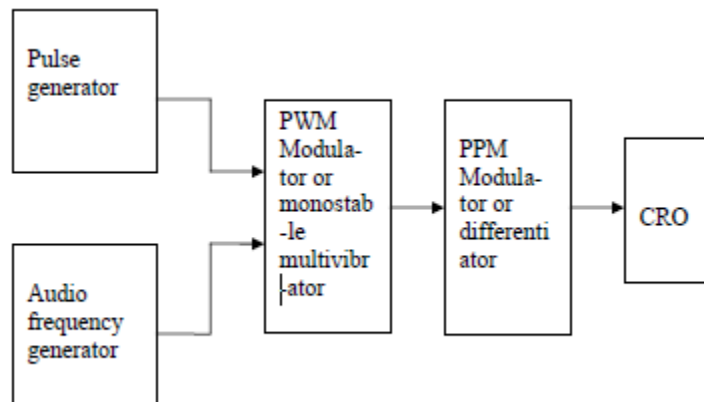

SPECIFICATION OF APPARATUS USED:-CRO, experimental kit, power supply, connecting leads.

PROCEDURE:--

1. Make the connection according to the block diagram.
2. Connect the audio frequency of 2 KHz, 2V to modulator.
4. Connect the PWM output to the PPM modulator.
4. Connect the PPM modulator output to CRO.
5. Switch ON the power supply.
6. Observe output on CRO

PRECAUTIONS:-

1. Do not use open ended wires for connecting to 230 V power supply.
2. Before connecting the power supply plug into socket, ensure power supply should be switched off
3. Ensure all connections should be tight before switching on the power supply.

4. Take the reading carefully.
5. Power supply should be switched off after completion of experiment.

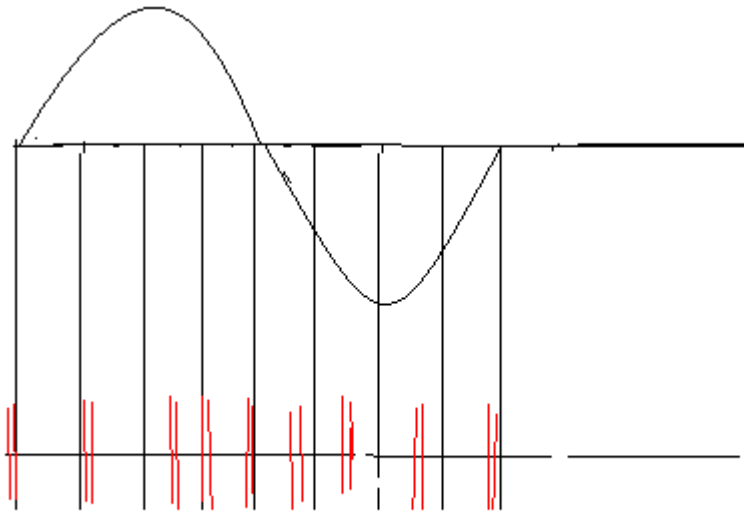
OBSERVATION DATA:**RESULT AND COMMENTS:**

The Pulse Position Modulated wave is obtained on CRO.

EXPERIMENT No.8

AIM: - - Study of Amplitude Shift Keying.

THEORETICAL CONCEPT:-

The binary ASK System was one of the earliest forms of digital modulation used in wireless telegraphy. This simplest form of digital modulation is no longer used widely in digital communication .Nevertheless it serves as a useful model which helps in understanding certain concepts.

In an ASK system, binary symbol 1 is represented by transmitting a sinusoidal carrier wave of fixed amplitude A_c and fixed frequency f_c for the bit duration T_b seconds whereas binary symbol 0 is represented by switching off the carrier for T_b seconds. This signal can be generated by switching off the carrier of a sinusoidal oscillator on and off for the prescribed periods indicated by the modulating pulse train. For this reason the scheme is also known as on-off keying (OOK).

Let the sinusoidal carrier be represented by

$$e_c(t) = A_c \cos(2\pi f_c t)$$

Then, the binary ASK signal can be represented by a wave $s(t)$ given by

$$S(t) = A_c \cos(2\pi f_c t) \text{ symbol 1}$$

$$= 0, \text{ symbol 0}$$

A typical ASK waveform is illustrated in figure for a binary data represented by

{10110101}

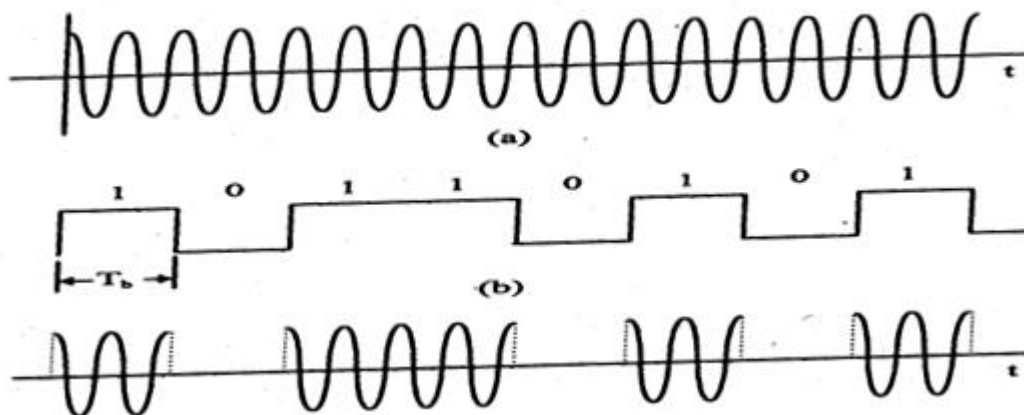

Figure1: ASK wave forms: (a) Unmodulated carrier (b) Unipolar bit sequence (c) ASK wave.

Generation Of ASK Signal

ASK signal can be generated by applying the incoming binary data (represented in unipolar form) and the sinusoidal carrier to the two inputs of a product modulator (balanced modulator) The resulting output is the ASK wave.

This is illustrated in figure modulation causes a shift of the baseband signal spectrum. The ASK signal which is basically the product of the binary sequence and the carrier signal.

EXPERIMENTAL SETUP:

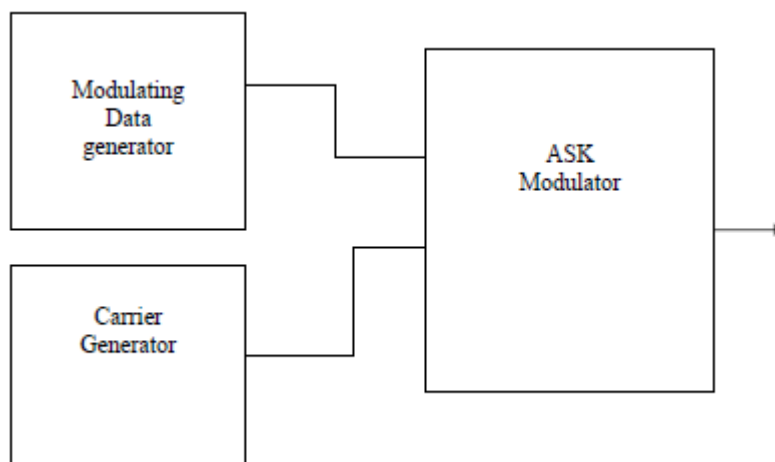

SPECIFICATION OF APPARATUS USED:-ASK modulation kit, CRO and connecting leads.

PROCEDURE:-

1. Make the connection according to the circuit diagram.
2. Connect the modulator output to CRO.
3. Observe output on CRO.

PRECAUTIONS:-

- I. Do not use open ended wires for connecting to 230 V power supply.
2. Before connecting the power supply plug into socket, ensure power supply should be switched Off.

3. Ensure all connections should be tight before switching on the power supply.
4. Take the reading carefully.
5. Power supply should be switched off after completion of experiment.

RESULT AND COMMENTS: - ASK output is obtained on CRO.

ECE DEPTT.

EXPERIMENT No.9

AIM:--Study of Frequency Shift Keying.

THEORETICAL CONCEPT:-

FSK is one of the basic modulation techniques for the transmission of digital data .If the frequency of the sinusoidal carrier is switched depending upon the input digital signal , then it is known as frequency shift keying. As the amplitude remains constant in FSK, so the effect of non-linear ties, noise interference is minimum on digital detection. So FSK is preferred over ASK.

Frequency shift keying consists of shifting of frequency of carrier from a mark frequency to a space frequency according to the base band digital signal. Frequency shift keying is identical to modulating an FM carrier with a binary digital signal

In an FSK system, two sinusoidal carrier waves of the same amplitude A_c but different frequencies f_{c1} and f_{c2} are used to represent binary symbols 1 and 0 respectively. It can be easily verified that binary FSK waveform is a superposition of two binary ASK waveforms, one with a frequency f_{c1} and other with a frequency f_{c2} . No discrete components appear in the signal spectrum of FSK signal. The main advantage of FSK lies in its easy hardware implementation.

Generation of FSK signal:-

The PSK signal can be generated by applying the incoming binary data to a frequency modulator. To the other input a sinusoidal carrier wave of constant amplitude A_c and frequency f_c is applied. As the modulating voltages changes from one level to another, the frequency modulator output changes its frequency in the corresponding fashion.

Detection of FSK signal:-

FSK can be demodulated by using coherent and non-coherent detector. The detector based on coherent detection requires phase and timing synchronization. Non coherent detection can be done by using envelop detector.

EXPERIMENTAL SETUP:

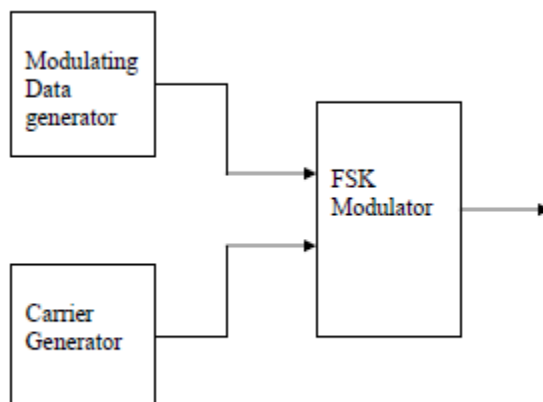

SPECIFICATION OF APPARATUS USED: - Data generator, FSK modulation kit, CRO and connecting leads.

PROCEDURE:-

1. Make the connection according to the block diagram.
2. Connect the modulator output to CRO.
3. Observe output on CRO.

PRECAUTIONS:-

1. Do not use open ended wires for connecting to 230 V power supply.
2. Before connecting the power supply plug into socket, ensure power supply should be switched off
3. Ensure all connections should be tight before switching on the power supply.
4. Take the reading carefully.
5. Power supply should be switched off after completion of experiment

OBSERVATION DATA:

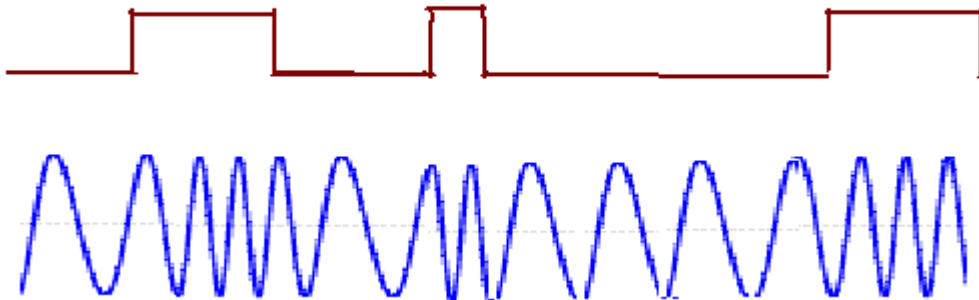

RESULT AND COMMENTS AND COMMENTS: - FSK output is obtained on CRO.

EXPERIMENT No.10

AIM: - To Study Differential pulse code modulation and Demodulation.

THEORETICAL CONCEPT:-

Meaning of DPCM – “Differential Pulse Code Modulation”, is a modulation technique invented by the British Alec Reeves in 1937. It is a digital representation of an analog signal where the magnitude of the signal is sampled regularly at uniform intervals.

Every sample is quantized to a series of symbols in a digital code, which is usually a binary code. PCM is used in digital telephone systems. It is also the standard form for digital audio in computers and various compact disc formats. Several PCM streams may be multiplexed into a larger aggregate data stream. This technique is called Time-Division Multiplexing.

TDM was invented by the telephone industry, but today the technique is an integral part of many digital audio workstations such as Pro Tools. In conventional PCM, the analog signal may be processed (e.g. by amplitude compression) before being digitized. Once the signal is digitized, the PCM signal is not subjected to further processing (e.g. digital data compression). Some forms of PCM combine signal processing with coding. Older versions of these systems applied the processing in the analog domain as part of the A/D process; newer implementations do so in the digital domain. These simple techniques have been largely rendered obsolete by modern transform-based signal compression techniques

In practical system bandwidth requirement for the transformation of information is very important aspect, since if bandwidth requirement is less more number of channels can be multiplexed on a single line and full utility of transmitting media is extracted out. In a system in which a baseband signal $m(t)$ is transmitted by sampling, there is available a scheme of transmission which is an alternative to transmitting the sample values at each sampling time. We can instead, at each sampling time, say the K th sampling time, transmit the difference between the sample value $m(k)$ at sampling time K and the sample value $m(K-1)$ at time $k-1$. If such changes are transmitted, then simply by adding up these changes we shall generate at the receiver a waveform identical in form to $m(t)$.

EXPERIMENTAL SETUP:

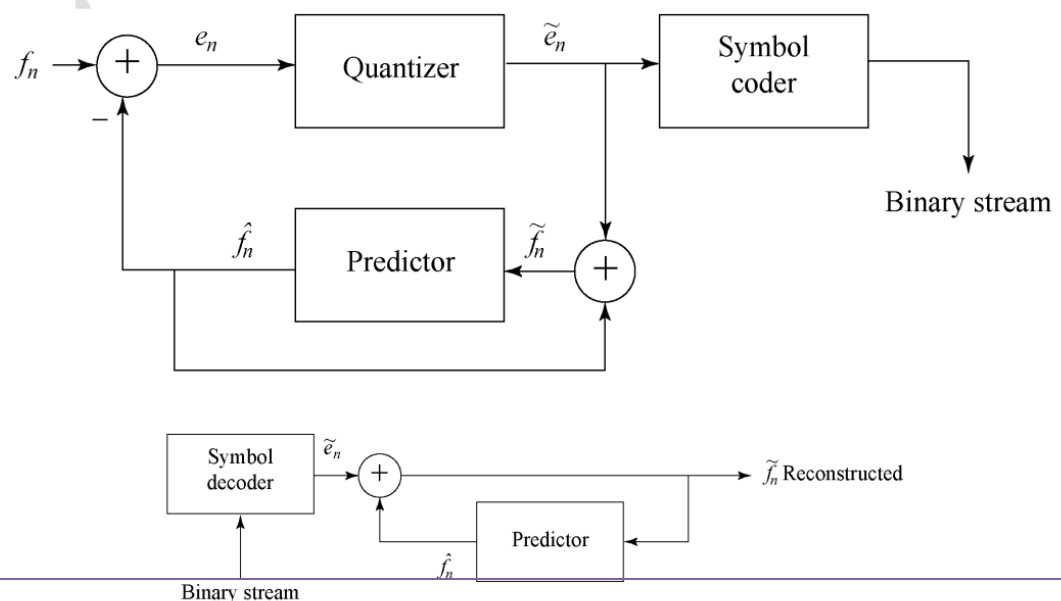

SPECIFICATION OF APPARATUS USED: - Trainer Kit, Power supply, Connecting Wires.

PROCEDURE:-

1. Make the connection according to the circuit diagram.
2. Observe output on CRO.

PRECAUTIONS:-

1. Do not use open ended wires for connecting to 230 V power supply.
2. Before connecting the power supply plug into socket, ensure power supply should be switched off
3. Ensure all connections should be tight before switching on the power supply.
4. Take the reading carefully.
5. Power supply should be switched off after completion of experiment

RESULT AND COMMENTS: - DPCM modulation and demodulation has been studied.